

DIN Module Enclosure SMB-2



Features

- * Designed to house up to 6 Hochiki DIN Modules
- * Quick-release screws
- * Polyurethane gasket provides IP66 protection
- * Corrosion free, resistant to most alkaline and acid
- * Temperature resistance to +70°C, Impact resistant, and Non-flammable
- * 32 knock-outs
- * Supplied with DIN Rail and fixings

Description

Model SMB-2 is an IP66 rated, grey (RAL7035) enclosure designed for use with the Hochiki range of DIN Modules. The SMB-2 features a selection of metric knock-outs and is supplied with a transparent black lid as standard. A grey opaque lid, SMB-2(LID), is also available (sold separately). The unit is supplied with a DIN Rail section (plus fixings) and will accept up to six Hochiki DIN Rail Modules, side-by-side. Used in conjunction with the SMB-ADAPTOR, an adaptor plate (sold separately), this enclosure can also house any of the PCB assemblies from the Hochiki Smart-Fix Module range or the CHQ-SIM, CHQPOM or CHQ-SOM "mini" modules (see over for further details).

Specification

Ordering codes	SMB-2 Base c/w transparent lid	SMB-2(LID) Opaque lid
Ingress Protection rating	IP66	N/A
Colour	Box - Grey (RAL7035) Lid - Transparent black	Grey (RAL7035)
Material	Box - Polystyrene Lid - Polycarbonate	Polystyrene
Weight (g)	900	495
Dimensions (mm)	L254 x W180 x H165	L254 x W180 x H92
DIN Rail dimensions (mm)	L216 x W35 ('top hat')	N/A
Knock-out configuration	Long sides	1 x M32/40 2 x M25/32 8 x M20
	Short sides	1 x M32/40 4 x M20
Suitable protection against	Weak alkali, strong alkali, alcohol, petrol, benzene, mineral oil, diesel, ammonia, vegetable oil, animal oil	

SMB-ADAPTOR – Typical Configurations

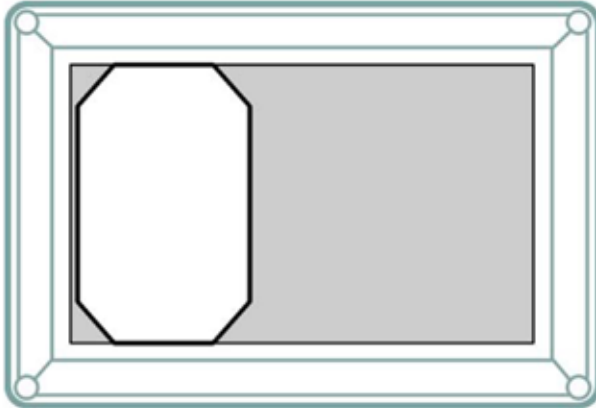

SMB-ADAPTOR with 1 CHQ-ADAPTOR (+ PCB)
(fitted portrait)

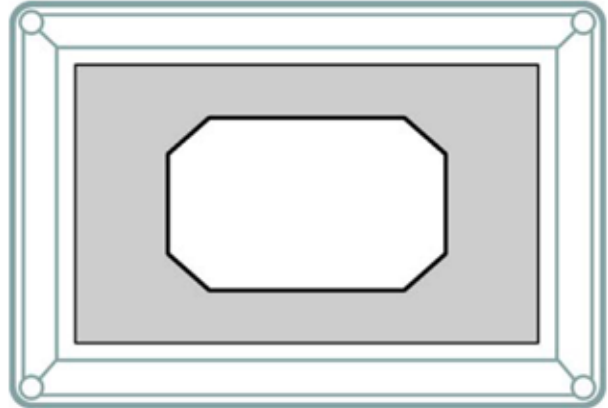

SMB-ADAPTOR with 1 CHQ-ADAPTOR (+ PCB)
(fitted landscape)

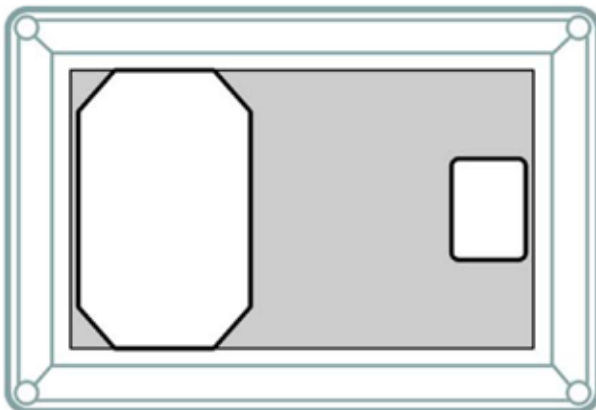

SMB-ADAPTOR with 1 CHQ-ADAPTOR (+ PCB) and 1 'mini' CHQ (for example, CHQ-POM)

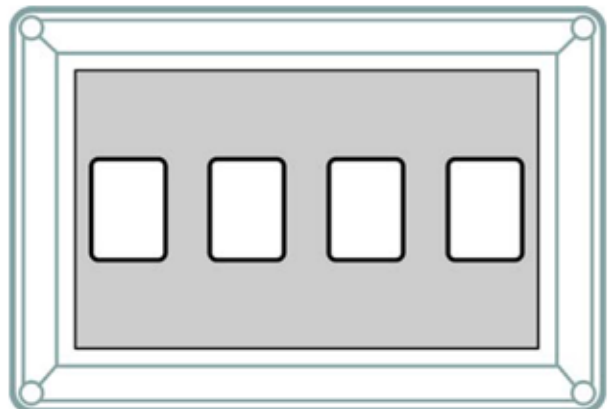

SMB-ADAPTOR with 4 'mini' CHQ (for example, CHQ-POM)

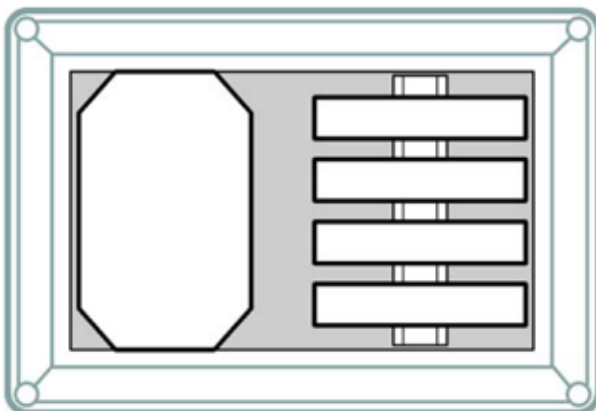

SMB-ADAPTOR with 1 CHQ-ADAPTOR (+ PCB) a DIN Rail and 4 CHQ-DIN Modules

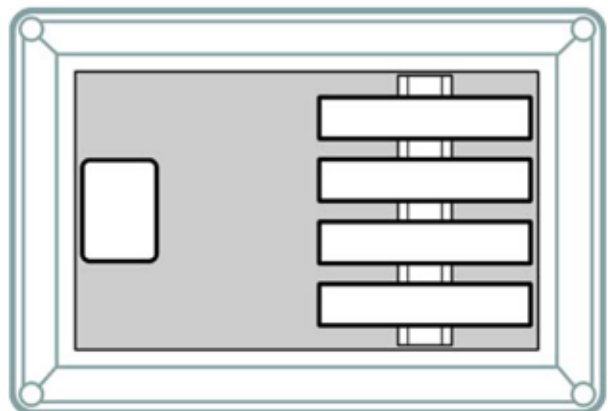

SMB-ADAPTOR with 1 'mini' CHQ (for example, CHQ-POM), a DIN Rail and 4 CHQ-DIN Modules